



LIMIT FDC-L91
Microprocessor Based Limit Controller

7524 West 98th Place
Bridgeview, IL 60455
Phone 888-751-5444
Fax 888-307-8014

UMOL911A-Rev1

User's Manual

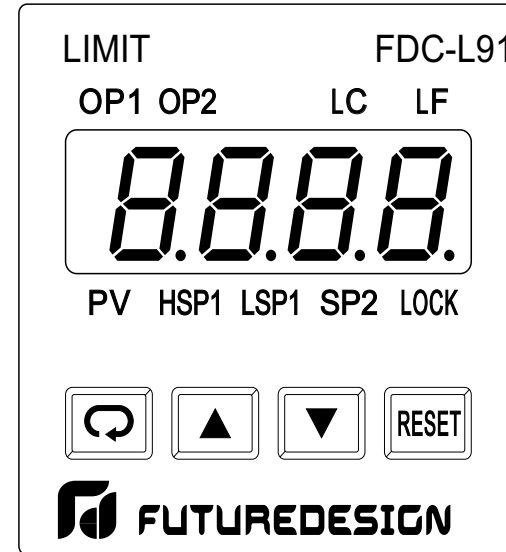

LIMIT L91
Microprocessor Based Limit Controller



Warning Symbol

This  Symbol calls attention to an operating procedure, practice, or the like, which, if not correctly performed or adhered to, could result in personal injury or damage to or destruction of part or all of the product and system. Do NOT proceed beyond a warning symbol until the indicated conditions are fully understood and met.

Use the Manual

- Installers Read Chapter 1, 2
- System Designer Read All Chapters
- Expert User Read Page 12

NOTE:

It is strongly recommended that a process should incorporate a LIMIT like the L91 which will shut down the equipment at a preset process condition in order to preclude possible damage to products or system.

Information in this user's manual is subject to change

Copyright August 2001, Future Design Controls, all rights reserved. No part of this publication may be reproduced, transmitted, transcribed or stored in a retrieval system, or translated into any language in any form by any means without the written permission of Future Design Controls.

Warranty

Future Design Controls warranties or representations of any sort regarding the fitness for use, or the application of its products by the Purchaser. The selection, application or use of Future Design products is the Purchaser's responsibility. No claims will be allowed for any damages or losses, whether direct, indirect, incidental, special or consequential. Specifications are subject to change without notice. In addition, Future Design reserves the right to make changes without notification to Purchaser to materials or processing that do not affect compliance with any applicable specification. Future Design products are warranted to be free from defects in material and workmanship for two years after delivery to the first purchaser for use. An extended period is available with extra cost upon request. Future Design's sole responsibility under this warranty, at Future Design's option, is limited to replacement or repair, free of charge, or refund of purchase price within the warranty period specified. This warranty does not apply to damage resulting from transportation, alteration, misuse or abuse.

RETURNS

No products return can be accepted without a completed Return Material Authorization (RMA) form.

User Interface

4-digit LED Displays: 0.4" (10mm),

Keypad: 4 keys

Programming Port: For automatic setup, calibration and testing.

Communication Port: Connection to PC for supervisory control.

Limit Control: High Limit, Low limit and High/Low Limit programmable

Digital Filter

Function: First order

Time Constant: 0, 0.2, 0.5, 1, 2, 5, 10, 20, 30, 60 seconds programmable

Environmental & Physical

Operating Temperature : -10°C to 50°C

Storage Temperature : -40°C to 60°C

Humidity : 0 to 90 % RH (non-condensing)

Insulation Resistance : 20 Mohms min. (at 500 VDC)

Dielectric Strength : 2000 VAC, 50/60 Hz for 1 minute

Vibration Resistance : 10 - 55 Hz, 10 m/s² for 2 hours

Shock Resistance : 200 m/s² (20 g)

Moldings : Flame retardant polycarbonate

Dimensions: 48 mm(W) X 48 mm(H) X 94 mm(D),
86 mm depth behind panel

Weight : 150 grams

Approval Standards

Safety : UL873 (11th edition, 1994)

CSA C22.2 No. 24-93

EN61010-1 (IEC1010-1)

FM Pending

Protective Class :

IP30 front panel, indoor use,

IP 20 housing and terminals (with protective cover)

EMC EN61326

Contents

	Page No	Page No
Chapter 1 Overview		
3-4 PV Shift -----		35
1-1 General-----	5	3-5 Digital Filter ----- 35
1-2 Ordering Code-----	6	3-6 Process Alarms ----- 36
1-3 Programming Port-----	7	3-7 RS-485 Communication 37
1-4 Keys and Display-----	7	3-8 Display Mode----- 38
1-5 Menu Overview-----	12	3-9 Signal Conditioner DC Power Supply ----- 38
1-6 Limit Control Operation-	13	3-10 Remote Reset----- 40
1-7 Parameter Descriptions-	16	3-11 Remote Lock----- 40
		3-12 Limit Annunciator----- 41
Chapter 2 Installation		
2-1 Unpacking-----	22	
2-2 Mounting-----	22	Chapter 4 Applications ----- 42
2-3 Wiring Precautions -----	23	Chapter 5 Calibration ----- 43
2-4 Power Wiring -----	25	Chapter 6 Specifications ----- 47
2-5 Sensor Installation Guidelines-----	25	
2-6 Thermocouple Input Wiring -----	26	
2-7 RTD Input Wiring -----	27	
2-8 Linear DC Input Wiring--	28	
2-9 Event Input Wiring-----	29	
2-10 Output 1 Wiring-----	30	
2-11 Output 2 Wiring-----	31	
2-12 RS-485 -----	32	
Chapter 3 Programming		
3-1 Process Input -----	33	
3-2 Limit Control-----	34	
3-3 Setpoint Range -----	34	

Figures & Tables

	Page No
Figure 1-1 Programming Port Location	7
Figure 1-2 Front Panel Display	8
Figure 1-3 Power Up Sequence	10
Figure 1-4 High Limit Operation	13
Figure 1-5 Low Limit Operation	14
Figure 1-6 High/Low Limit Operation	15
Figure 2-1 Mounting Diagram	23
Figure 2-2 Lead Termination	24
Figure 2-3 Rear Terminal Connection Diagram	24
Figure 2-4 Power Supply Connections	25
Figure 2-5 Thermocouple Input Wiring	27
Figure 2-6 RTD Input Wiring	27
Figure 2-7 Linear Voltage Input Wiring	28
Figure 2-8 Linear Current Input Wiring	28
Figure 2-9 Event Input Wiring	29
Figure 2-10 Output 1 Wiring	30
Figure 2-11 Output 2 Wiring	31
Figure 2-12 RS-485 Wiring	32
Figure 3-1 Conversion of Linear Process Input	33
Figure 3-2 Filter Characteristics	35
Figure 3-3 Normal Process Alarm	37
Figure 3-4 Latching Process Alarm	37
Figure 3-5 DC Power Supply Application	39
Figure 3-6 Remote Reset Application	40
Figure 3-7 Remote Lock Application	40
Figure 4-1 Over Temperature w/ Remote Reset	42
Figure 5-1 Flow chart for Manual Calibration	44
Figure 5-2 Cold Junction Calibration Setup	45
Figure 5-3 RTD Calibration	46
Table 1-1 Display Form of Characters	9
Table 6-1 Input Characteristics	48

Event Input

Logic Low: -10V minimum, 0.8V maximum.

Logic High: 2V minimum, 10V maximum.

Functions: Remote reset, remote lockout.

Output 1 / Output 2

Relay Rating: 2A/240 VAC, life cycles 200,000 for resistive load.

Pulsed Voltage: Source Voltage 5V, current limiting resistance 66 ohms.

Triac (SSR) Output

Rating: 1/240 VAC

Inrush Current: 20A for 1 cycle

Min. Load Current: 50 mA rms

Max. Off-state Leakage: 3 mA rms

Max. On-state Voltage: 1.5 V rms

Insulation Resistance: 1000 Mohms min. at 500 VDC

Dielectric Strength: 2500 VAC for 1 minute

DC Voltage Supply Characteristics (Installed at Output 2)

Type	Tolerance	Max. Output Current	Ripple Voltage	Isolation Barrier
20 V	A0.5 V	25 mA	0.2 Vp-p	500 VAC
12 V	A0.3 V	40 mA	0.1 Vp-p	500 VAC
5 V	A0.15 V	80 mA	0.05 Vp-p	500 VAC

Data Communication

Interface : RS-485 (up to 247 units)

Protocol : Modbus Protocol RTU mode

Address : 1 - 247

Baud Rate : 0.3 ~ 38.4 Kbits/sec

Data Bits : 8 bits

Parity Bit : None, Even or Odd

Stop Bit : 1 or 2 bits

Communication Buffer : 50 bytes

Characteristics:

Type	Range	Accuracy @ 25 °C	Input Impedance
J	-120°C- 1000°C (-184°F - 1832°F)	±2 °C	2.2 MΩ
K	-200°C- 1370°C (-328°F - 2498°F)	±2 °C	2.2 MΩ
T	-250°C- 400°C (-418°F - 752°F)	±2 °C	2.2 MΩ
E	-100°C- 900°C (-148°F - 1652°F)	±2 °C	2.2 MΩ
B	0°C- 1820°C (- 32°F - 3308°F)	±2 °C (200°C - 1820°C)	2.2 MΩ
R	0°C- 1767.8°C (- 32°F - 3214°F)	±2 °C	2.2 MΩ
S	0°C- 1767.8°C (- 32°F - 3214°F)	±2 °C	2.2 MΩ
N	-250°C- 1300°C (-418°F - 2372°F)	±2 °C	2.2 MΩ
L	-200°C- 900°C (-328°F - 1652°F)	±2 °C	2.2 MΩ
PT100 (DIN)	-210°C- 700°C (-346°F - 1292°F)	±0.4 °C	1.3 KΩ
PT100 (JIS)	-200°C- 600°C (-328°F - 1112°F)	±0.4 °C	1.3 KΩ
mV	-8mV- 70mV	±0.05 %	2.2 MΩ
mA	-3mA- 27mA	±0.05 %	100 Ω
V	-1.3V- 11.5V	±0.05 %	510 KΩ

Table 6-1 Input Characteristics

Chapter 1 Overview

1-1 General

The limit control L91 is a microprocessor based high or low limit safety device with a latching output. The relay contacts open if an abnormal condition during the process is higher than the high limit set point or lower than the low limit set point.

The unit is powered by 90-264 VAC or an optional 11-26 VAC/VDC power supply. It incorporates a 2 amp. form C relay for limit control, a universal input which is fully programmable for RTD PT100, thermocouple types J, K, T, E, B, R, S, N, L, 0~60mVolt, Volt* and Milliamps*. An option port is available for one of the following functions: alarm output, RS-485 communication interface, DC power supply output, limit annunciator output and event input. Alternative output options include SSR drive and Triac. The input signal is digitized by using a 18-bit A to D converter. Its fast sampling rate (10 times/second) allows the L91 to respond quickly to input changes.

Digital communication RS-485 is available as an additional option. This option allows L91 to be integrated with supervisory control system. An alarm output is another option. A variety of alarm function and alarm modes can be programmed for a specific application. The DC power supply output option is used for an external sensor or transmitter. The event input option can be programmed for remote reset or remote lock signal input. The limit annunciator option can be used to energize an external audible alarm when limit is reached.

Three kinds of method can be used to program L91. 1. use keys on front panel to program the unit manually, 2. Use a PC and setup software to program the unit via RS-485 port and 3. Use P11A, a hand-held programmer, to program the unit via programming port.

High accuracy, maximum flexibility, fast response and simple user friendly prompts are the main features of L91.

NOTE: * Volt and Milliamp Inputs are NOT FM Approved.

1-2 Ordering Code

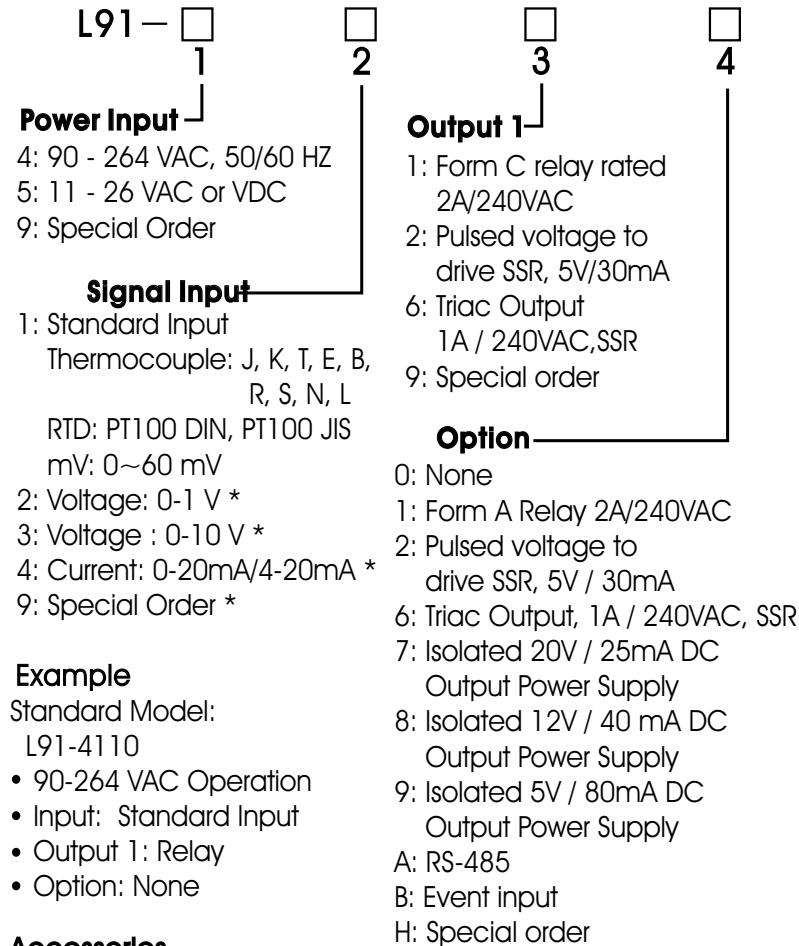

Example

Standard Model:
L91-4110

- 90-264 VAC Operation
- Input: Standard Input
- Output 1: Relay
- Option: None

Accessories

OM94-6 = Isolated 1A / 240VAC Triac Output Module (SSR)
DC94-1 = Isolated 20V / 25mA DC Output Power Supply
DC94-2 = Isolated 12V / 40mA DC Output Power Supply
DC94-3 = Isolated 5V / 80mA DC Output Power Supply
CM96-1 = Isolated RS-485 Interface Module
EI96-1 = Event Input Module
UM0L91 1A-Rev7 = L91 User's Manual
NOTE: * Volt and Milliamp Inputs are NOT FM Approved.

Chapter 6 Specifications

Power

90-264 VAC, 49-63 Hz, 10 VA, 5W maximum
11-26 VAC/VDC, 10 VA, 5W maximum

Input

Resolution: 18 bits

Sampling: 10 times/second

Maximum Rating: -2 VDC minimum, 12 VDC maximum
(1 minute for mA input)

Temperature Effect: A1.5 $\mu\text{V}/^\circ\text{C}$

Sensor Lead Resistance Effect:

T/C: 0.2 $\mu\text{V}/\text{ohm}$

3-wire RTD: 2.6 $^\circ\text{C}/\text{ohm}$ of resistance difference of two leads

2-wire RTD: 2.6 $^\circ\text{C}/\text{ohm}$ of resistance sum of two leads

Burn-out Current: 200nA

Common Mode Rejection Ratio (CMRR): 120db

Sensor Break Detection:

Sensor open for TC, RTD and mV inputs,
below 1 mA for 4-20 mA input,
below 0.25V for 1-5 V input,
unavailable for other inputs.

Sensor Break Responding Time:

Within 4 seconds for TC, RTD and mA inputs,
0.1 second for 4-20 mA and 1-5V inputs.

Step 4: Calibrate **gain of cold junction.**

Setup the equipment same as step 3. The unit under calibration is power in a still-air room with temperature 50A3 BC. Allow at least 20 minutes for warming up. The calibrator source is set at 0.00°C with internal compensation mode. Press  for at least 4 seconds. The display will blink a moment. If the display didn't blink, then the calibration failed.

Step 5: Calibrate **RTD reference voltage.**

Send a 100 ohms signal to terminal 3, 4 and 5 according to **Figure 5-3.**

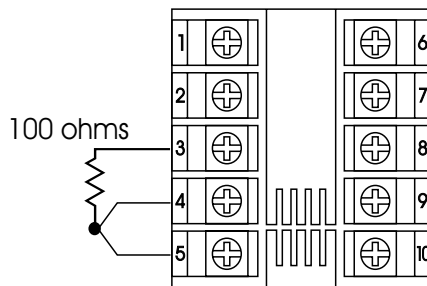



Figure 5-3
RTD Calibration

Press  for at least 4 seconds. The display will blink a moment. If the display didn't blink, then the calibration failed.

Step 6: Calibrate **RTD serial resistance.**

Change the ohm's value of the calibrator to 300 ohms. Press  for at least 4 seconds. The display will blink a moment. If the display didn't blink, then the calibration failed.

Related Products

- P11A = Hand-held Programmer for L91,C91 Series Controller
- SNA10A = Smart Network Adaptor for Third Party Software,
Converts 255 channels of RS-485 or RS-422 to
RS-232 Network
- SNA10B = Smart Network Adaptor for FD-Net Software, Converts
255 channels of RS-485 or RS-422 to RS-232 Network

1-3 Programming Port

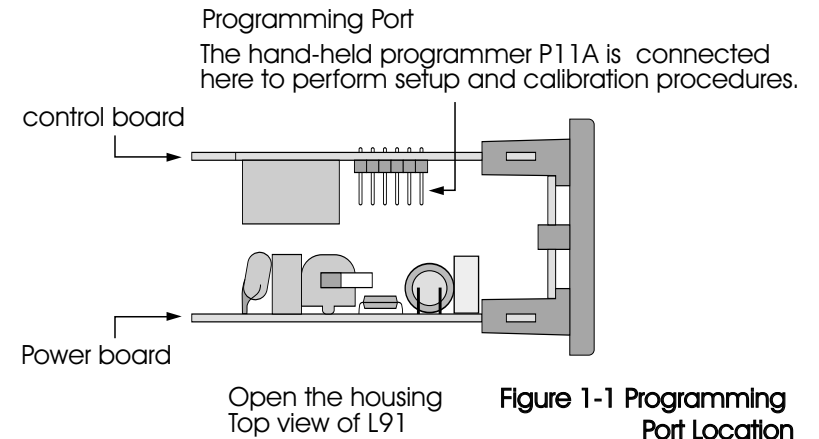

Figure 1-1 Programming
Port Location

Note: The programming port is used for off-line setup and calibration procedures only. Do not attempt to make any connection to these jumpers when the unit is on-line. Port is for bench setup only.

1-4 Keys and Display

KEYPAD OPERATION

SCROLL KEY

This key is used to:

1. Select a setpoint to be displayed.
2. Select a parameter to be viewed or adjusted.
3. Advance display from a parameter code to the next parameter code

ENTER KEY  4 seconds, 8 seconds

Press the scroll key for 4 seconds the display will enter the setup menu. Press this key for 8 seconds to enter the calibration mode.

UP KEY 

This key is used to increase the selected parameter value during the lock indicator is off.

DOWN KEY 

This key is used to decrease the selected parameter value during the lock indicator is off.

RESET KEY 

This key is used to:

1. Reset the limit condition after the process is within the limit.
2. Revert the display to the normal display.
3. Reset the latching alarm.
4. Reset the limit annunciator.

Note: If the RESET key is left pressed, only ONE reset operation will occur. If the unit subsequently goes into a state where reset is required again, the RESET key (or remote reset contacts) must be released (opened) and pressed (closed) again.

UNLOCK KEY  4 seconds

Press the RESET key for 4 seconds to enable up/down key function, and the lock indicator led will be extinguished.

However, this function is disabled when remote lock is selected for EIFN (Event input function). **See section 3-16.**

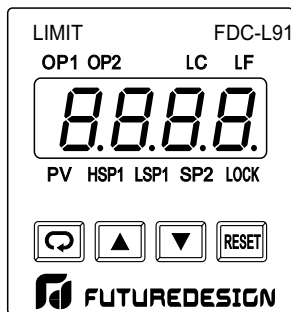



Figure 1-2 Front Panel Display

INDICATORS

- Op1: Output 1 status indicator
Op2: Output 2 status indicator
LC: Degree C indicator
LF: Degree F indicator
PV: Process value
HSP1: High limit set point 1
LSP1: Low limit set point 1
SP2: Set point 2 for output 2
LOCK: Lock status indicator

Step 2: Calibrate Gain of A to D converter.

Send a span signal to terminal 4 and 5 with correct polarity. The span signal is 60 mV for thermocouple input, 1V for 0-1V input, 10V for 0-10V input and 20mA for 0-20 mA input. Press  for at least 4 seconds. The display will blink a moment. If the display didn't blink, then the calibration failed.

Step 3: Calibrate offset of cold junction.

Setup the equipment according to the following diagram for calibrating the cold junction compensation. Note that a K type thermocouple must be used.

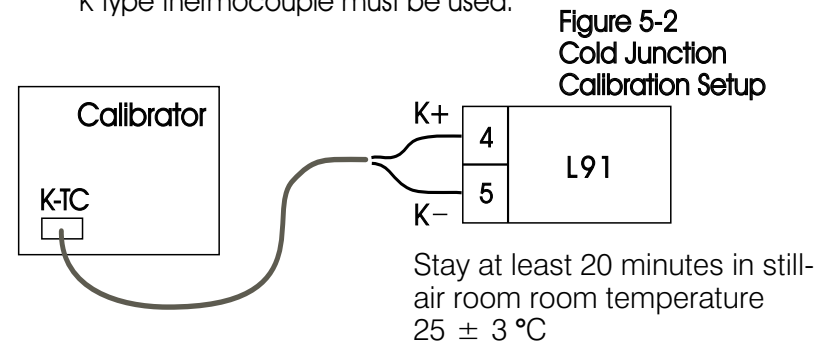

The 5520A calibrator is configured as K type thermocouple output with internal compensation. Send a $0.00 \text{ }^\circ\text{C}$ signal to the unit under calibration.

The unit under calibration is powered in a still-air room with temperature $25 \pm 3 \text{ }^\circ\text{C}$. Allow at least 20 minutes for warming up.

Press  for at least 4 seconds. The display will blink a moment. If the display didn't blink, then the calibration failed.

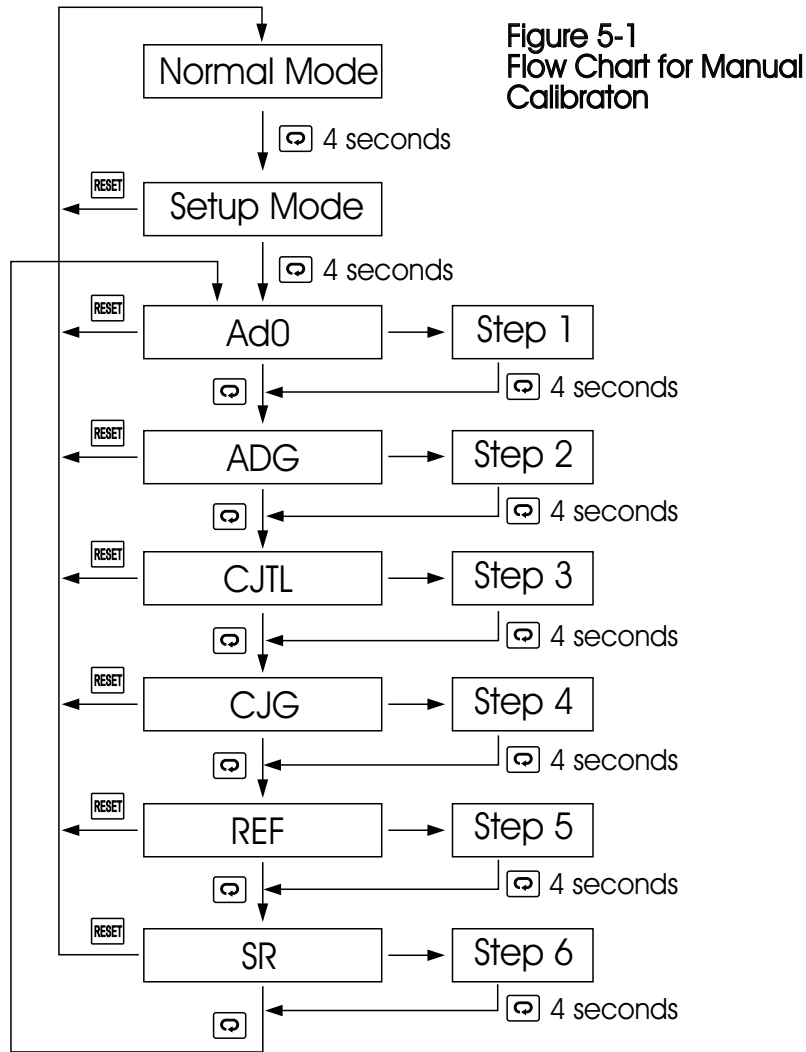

Step1: Calibrate **Zero** of A to D converter.
Short terminal 4 and 5, then press for at least 4 seconds.
The display will blink a moment. If the display didn't blink,
then the calibration has failed.

DISPLAY FORM

Table 1-1 Display Form of Characters

A	<i>A</i>	E	<i>E</i>	I	<i>I</i>	N	<i>n</i>	S	<i>S</i>	X	
B	<i>b</i>	F	<i>F</i>	J	<i>J</i>	O	<i>o</i>	T	<i>t</i>	Y	<i>y</i>
C	<i>C</i>	G	<i>G</i>	K	<i>K</i>	P	<i>P</i>	U	<i>u</i>	Z	
c	<i>c</i>	H	<i>H</i>	L	<i>L</i>	Q		V	<i>v</i>	?	<i>?</i>
D	<i>d</i>	h	<i>h</i>	M	<i>m</i>	R	<i>r</i>	W		=	<i>=</i>

▣: These characters are displayed differently.

How to display a 5-digit number :

For a number with decimal point the display will be shifted one digit right:
-199.99 will be displayed as -199.9, 4553.6 will be displayed as 4553

For a number without decimal point the display will be divided into two alternating phases:

-19999 will be displayed as:

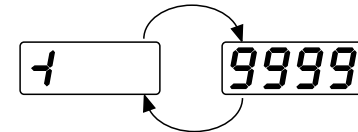

45536 will be displayed as:

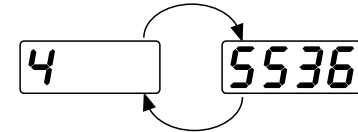

-9999 will be displayed as:

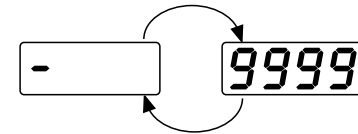

NORMAL DISPLAY

During normal operation, the unit can be configured to display the process value, high limit or low limit set point (HSP1 or LSP1 dependent on OUT1 selection) or the word SAFE.

ABNORMAL DISPLAY

Whenever the process is outside the normal range, the process value will be displayed.

SENSOR BREAK DISPLAY

If a break is detected in the sensor circuit, the display will show:

SEn.b

A-D FAILURE DISPLAY

If failure is detected in the A-D converter circuit, the display will show:

AdEr

POWER UP SEQUENCE

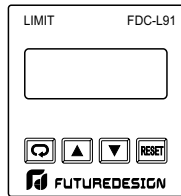

All segments of display and indicators are left off for 0.5 second.

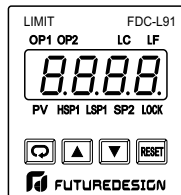

All segments of display and indicators are lit for 1 second.

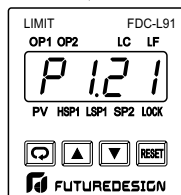

Display program code of the product for 1 second. The left diagram shows program no. 1 with version 21.

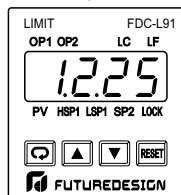

Display Date Code for 1 second. The left diagram shows Year 2001, Month February (2), Date 25th. This means that the product is produced on February 25th, 2001. Note that the month code **A** is for **October**, **B** is for **November** and **C** is for **December**.

Chapter 5 Calibration



Do not proceed through this section unless there is a definite need to re-calibrate the controller. Otherwise, all previous calibration data will be lost. Do not attempt re-calibration unless you have appropriate calibration equipment. If calibration data is lost, you will need to return the unit to your supplier who may charge you a service fee to re-calibrate the unit.



Entering calibration mode will break the control loop. Make sure that if the system is allowable to apply calibration mode.

Equipment needed for calibration:

- (1) A high accuracy calibrator (Fluke 5520A Calibrator recommended) with following function:
 - 0-100mA millivolt source with $\pm 0.005\%$ accuracy
 - 0-10V voltage source with $\pm 0.005\%$ accuracy
 - 0-20mA current source with $\pm 0.005\%$ accuracy
 - 0-300 ohm resistant source with $\pm 0.005\%$ accuracy
- (2) A test chamber providing 25°C - 50°C temperature range
- (3) A switching network (SCANNER 80, optional for automatic calibration)
- (4) A calibration fixture equipped with programming units (optional for automatic calibration)
- (5) A PC with calibration software FD-Net and Smart Network Adaptor SNA10B (optional for automatic calibration)

Since each unit needs 30 minutes to warm up before calibration, calibrating one unit each is inefficient. An automatic calibration system for small quantity well as for unlimited quantity is available upon request.

The calibration procedures described in the following are a step by step **manual procedures**.

Apply Enter Key (press  for 8 seconds) to enter the calibration mode. see **Figure 5-1**.

Chapter 4 Application

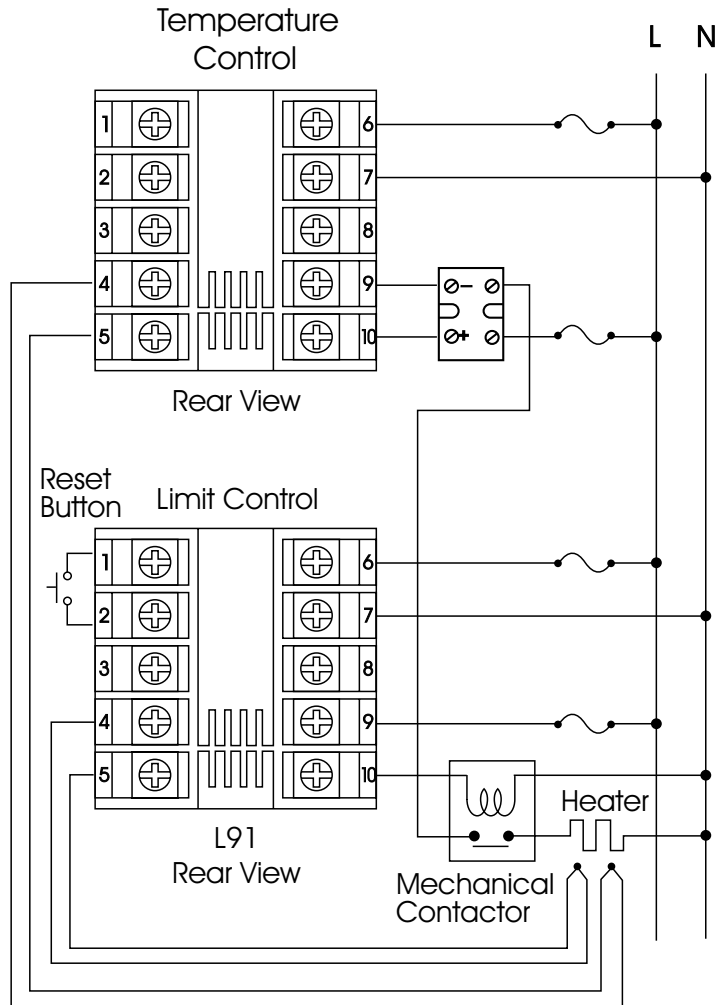
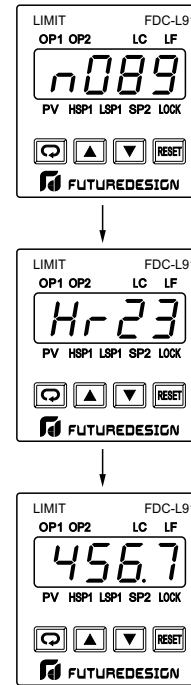

Figure 4-1 Over Temperature Protection with Remote Reset



Display the serial number (001~999) for 1 second.

Display the hours used for 2 seconds. The left diagram shows that the unit has been used for 23456.7 hours since production.

Figure 1-3 Power Up Sequence

1-5 Menu Overview

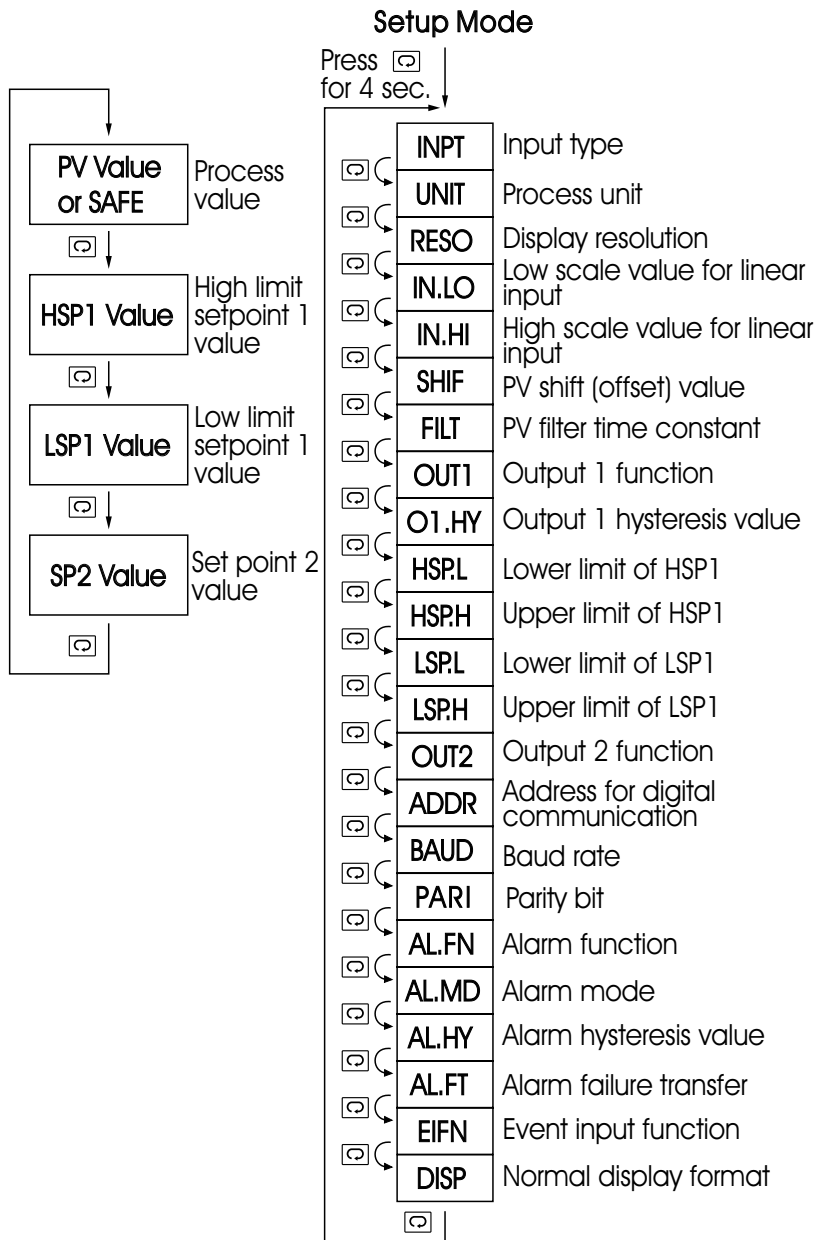

3-12 Limit Annunciator Output

If **L_AN** (Limit annunciator) is selected for **OUT2**, the output 2 will act as a Limit Annunciator. If the limit is or has been reached the Annunciator output will be enabled. If the **RESET** key is depressed, and the limit condition still exists the Annunciator Output **ONLY** will be deenergized. This output is effective as a audible alarm contact for when a limit condition occurs. It allows the audible alarm to be silenced even though the limit is still

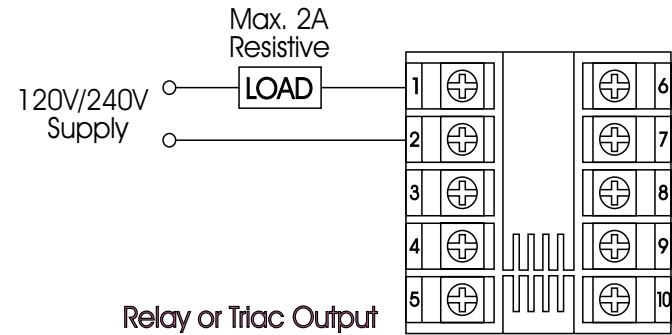

3-10 Remote Reset

If EIFN is selected for OUT2 and REST is selected for EIFN, terminals 1 & 2 will act as remote reset input. Pressing remote reset button will perform the same function as pressing the RESET key. Refer to section 1-4 for RESET key function.

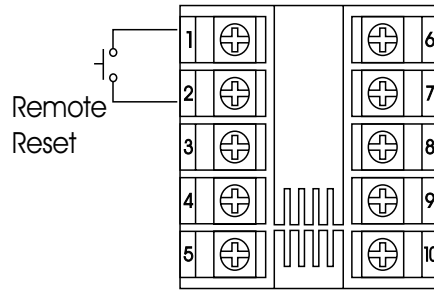

Setup
 OUT2 = EIFN
 EIFN = REST

Figure 3-6 Remote Reset Application

3-11 Remote Lock

If EIFN is selected for OUT2 and LOCK is selected for EIFN, terminals 1 & 2 will act as remote lock input. Turning the remote lock switch on will keep all the parameter setting from been changed.

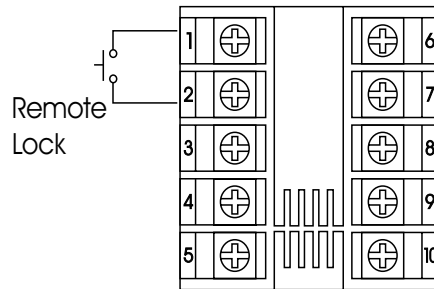

Setup
 OUT2 = EIFN
 EIFN = LOCK

Figure 3-7 Remote Lock Application

Note 1. The flow charts show a complete listing of parameters. For the actual application the number of available parameters is dependent on the setup conditions, and should be less than that shown in the flow charts.

Note 2. Press  key for 4 seconds to enable up/down key function, and the LOCK indicator led will be extinguished.

1-6 Limit Control Operation

HIGH LIMIT OPERATION

If Hi. is selected for OUT1, the unit will perform high limit control. When power is applied the OUT1 relay is de-energized. After 6.5 seconds self-test period, if the process is below the high limit set point (HSP1), the output 1 relay will be energized and OP1 indicator will go off. If the process goes above the high limit set point, the relay will be de-energized, the OP1 indicator will go on and the display will show the process value. After the process falls below the high limit set point and the RESET key is pressed or the remote reset input is applied, the relay will be energized and the OP1 indicator will go off.

NOTE: Hysteresis is safe-sided.

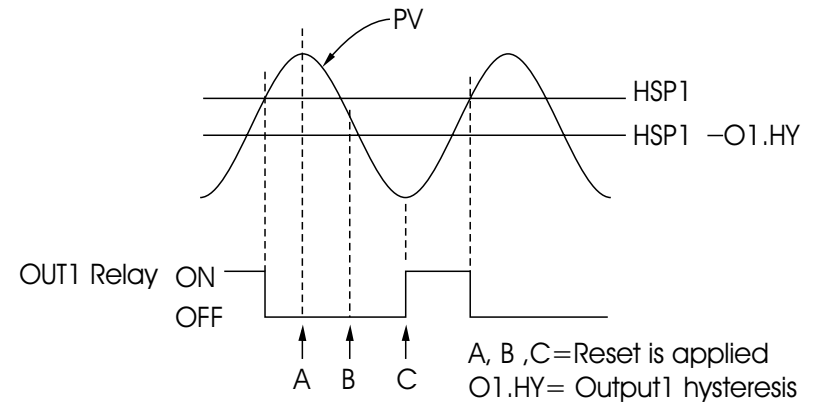

Figure 1-4 High Limit Operation

LOW LIMIT OPERATION

If Lo. is selected for OUT1, the unit will perform low limit control. When power is applied the OUT1 relay is de-energized. After 6.5 seconds self-test period, if the process is above the low limit set point (LSP1), the output 1 relay will be energized and OP1 indicator will go off. If the process goes below the low limit set point, the relay will be de-energized, the OP1 indicator will go on and the display will show the process value. After the process rises above the low limit set point and the RESET key is pressed or the remote reset input is applied, the relay will be energized and the OP1 indicator will go off.

NOTE: Hysteresis is safe-sided.

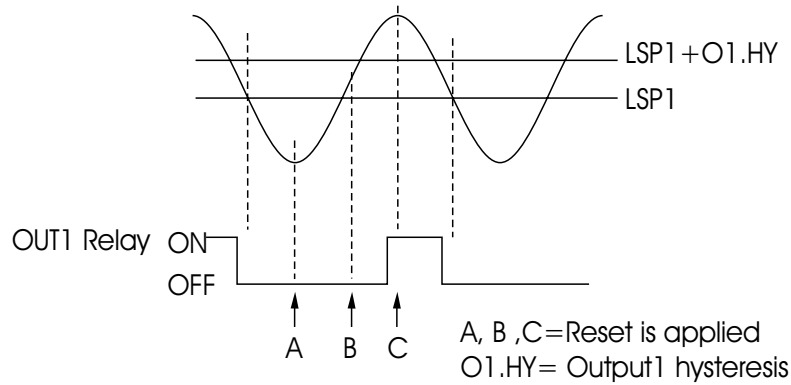
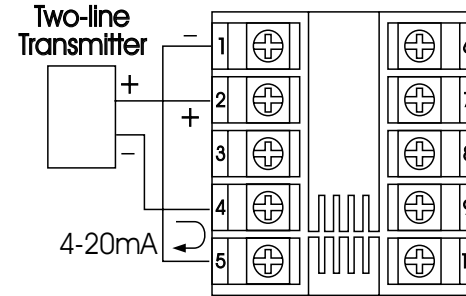
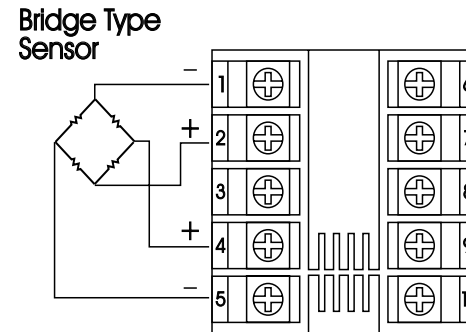
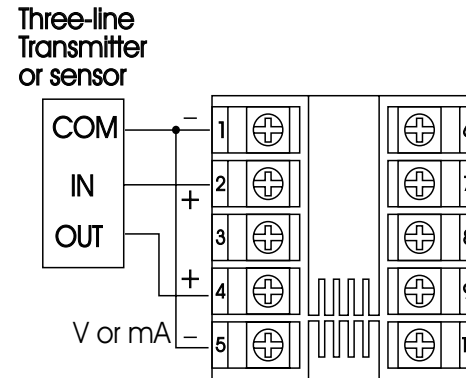

Figure 1-5 Low Limit Operation



Set
OUT2 = **dCPS**
DC Power Supply

Figure 3-5
DC Power Supply
Application



Caution:

Don't use the DC power supply beyond its rating current to avoid damage.
Purchase a correct voltage to suit your external devices. See ordering code in section 1-2.

Select COMM for OUT2 in setup menu, the output 2 will perform RS-485 interface with **Modbus RTU Mode** protocol.

Setup

1. Select COMM for OUT2
2. Set an unequal address (ADDR) for those units which are connected to the same port.
3. Set the Baud Rate (BAUD) and Parity Bit (PARI) such that these values are accordant with PC setup conditions.

3-8 Display Mode

The DISP in the setup menu is used to select the display format for the normal condition. If PV is selected, the display will indicate the process value. If SP1 is selected, the display will indicate HSP1 value for high limit control (OUT1 = HI) and high/low limit control (OUT1 = HI.LO) or indicate LSP1 value for low limit control (OUT1 = LO). If SAFE is selected, the display will indicate the word SAFE for the normal condition.

However the display will indicate the process value if the process value goes beyond high limit or low limit. If an error condition occurs, the display will indicate the error symbol.

The SAFE display will return when the process has returned to within SAFE values. Depressing reset key will reset output relay.

3-9 Signal Conditioner DC Power Supply

Three types of isolated DC power supply are available to supply an external transmitter or sensor. These are 20V rated at 25mA, 12V rated at 40 mA and 5V rated at 80 mA. The DC voltage is delivered to the output 2 terminals by selecting DCPS for OUT2 in setup menu.

HIGH/LOW LIMIT OPERATION

If Hi.Lo is selected for OUT1, the unit will perform high/low limit control. When power is applied the OUT1 relay is de-energized. After 6.5 seconds self-test period, if the process is below the high limit set point (HSP1) and above the low limit set point (LSP1), the output 1 relay will be energized and OP1 indicator will go off. If the process goes above the high limit set point or below the low limit set point, the relay will be de-energized, the OP1 indicator will go on and the display will show the process value. After the process is within the normal operation range, and the RESET key is pressed or the remote reset input is applied, the relay will be energized and the OP1 indicator will go off. NOTE: Hysteresis is safe-sided.

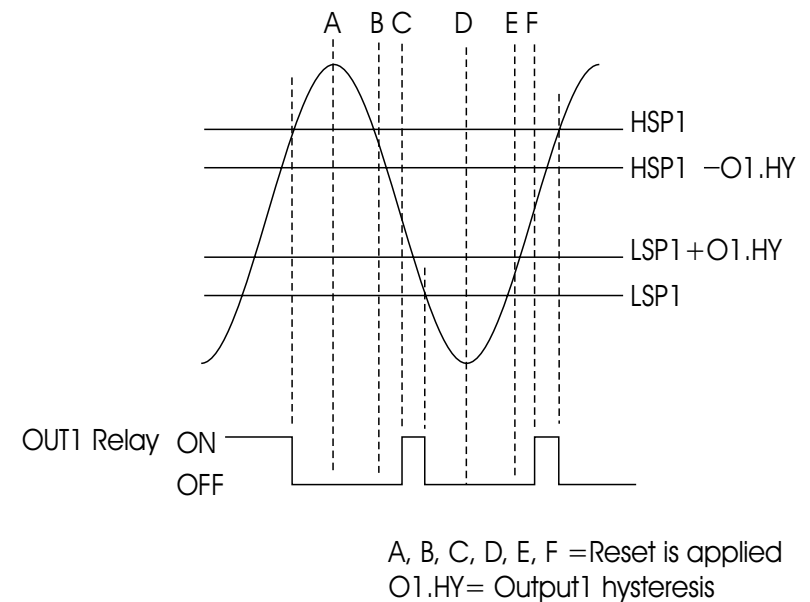

Figure 1-6 High/Low Limit Operation

1-7 Parameter Descriptions

Parameter Notation	Parameter Description	Range	Default Value
HSP1	High Limit Set point 1	Low: HSPL High: HSP.H	100.0 °C (212.0 °F)
LSP1	Low Limit Set point 1	Low: LSPL High: LSP.H	0 °C (32.0 °F)
SP2	Set point 2 Value for Output 2	See Table 6-1	90.0 °C (194.0 °F)
INPT	Input Type Selection	0 J_tC : J type thermocouple 1 K_tC : K type thermocouple 2 T_tC : T type thermocouple 3 E_tC : E type thermocouple 4 B_tC : B type thermocouple 5 R_tC : R type thermocouple 6 S_tC : S type thermocouple 7 N_tC : N type thermocouple 8 L_tC : L type thermocouple 9 Pt100 ohms DIN curve 10 Pt100 ohms JIS curve	1 (0)

Examples:

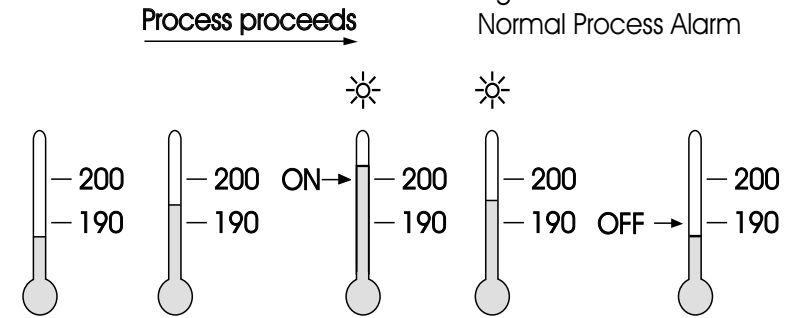

Figure 3.3
Normal Process Alarm

SP2 = 200 AL.HY = 10.0
AL.MD = LTCH AL.FN = PV.H.A

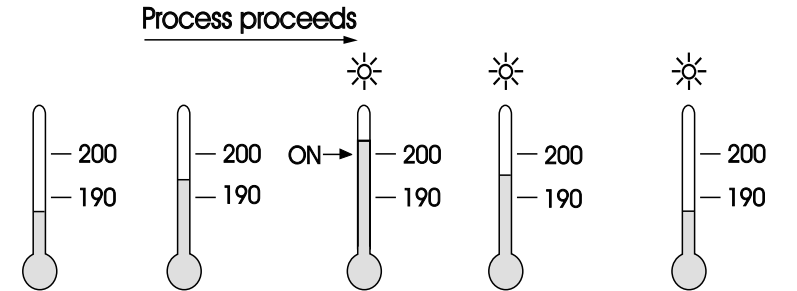

Figure 3.4
Latching Process Alarm

3-7 RS-485 Communication

Using a PC for data communication is the most economic way. The signal is transmitted and received through the PC communication Port (generally RS-232). Since a standard PC can't support RS-485 port, a network adaptor (such as SNA10A, SNA10B) has to be used to convert RS-485 to RS-232 for a PC if RS-485 is required for the data communication. Many RS-485 units (up to 247 units) can be connected to one RS-232, that is a PC with 4 comm ports can communicate with 988 units.

3-6 Process Alarms

The output 2 will perform process alarm function by selecting ALM for OUT2 and PV.H.A or PV.L.A for AL.FN. If PV.H.A is selected the alarm will perform process high alarm. If PV.L.A is selected the alarm will perform process low alarm. The process alarm sets an absolute trigger level. When the process exceeds that absolute trigger level an alarm occurs. The trigger level is determined by SP2 (Set point 2 value) and AL.HY (Alarm hysteresis value). The hysteresis value is introduced to avoid interference action of alarm in a noisy environment. Normally AL.HY can be set with a minimum value(0.1).

Trigger levels for process high alarm are SP2 and SP2 + AL.HY.
Trigger level for process low alarm are SP2 - AL.HY and Sp2.

There are two types of alarm mode can be selected, these are: normal alarm and latching alarm.

Normal Alarm: AL.MD= NORM

When a normal alarm is selected, the alarm output is de-energized in the non-alarm condition and energized in an alarm

Latching Alarm: AL.MD= LTCH

If a latching alarm is selected, once the alarm output is energized, it will remain unchanged even if the alarm condition has been cleared unless the power is shut off or the RESET key (or remote reset button) is pressed.

Failure Transfer: AL.FT = OFF or ON

In case of **Sensor Break** or **A-D Failure** occurs, the alarm output will be on or off according to the selection of AL.FT.

Examples:

SP2 = 200 AL.HY = 10.0
AL.MD = NORM AL.FN = PV.H.A

Parameter Notation	Parameter Description	Range	Default Value
INPT	Input Type Selection	11 4-20 : 4~20 mA linear current* 12 0-20 : 0~20 mA linear current* 13 0-60 : 0~60 mV linear voltage 14 0-1V : 0~1 V linear voltage* 15 0-5V : 0~5 V linear voltage* 16 1-5V : 1~5 V linear voltage* 17 0-10 : 0~10V linear voltage*	1 (0)
UNIT	Process Unit	0 0C : Degree C unit 1 0F : Degree F unit 2 Pu : Process unit	0 (1)
RESO	Display Resolution	0 no.dP : No decimal point 1 1-dP : 1 decimal point 2 2-dP : 2 decimal point 3 3-dP : 3 decimal point	1
IN.LO	Low Scale Value for Linear Input	Low: -19999 High: IN.HI	0

NOTE: Inputs 11, 12, 14, 15, 16, and 17 are NOT FM Approved.

Parameter Notation	Parameter Description	Range	Default Value
IN.HI	High Scale Value for Linear Input	Low: IN.LO High: 45536	100.0
SHIF	PV Shift (offset) Value	Low: -200.0 °C (-360.0 °F) High: 200.0 °C (360.0 °F)	0.0
FILT	PV Filter Time Constant	0 0 : 0 second time constant 1 0.2 : 0.2 second time constant 2 0.5 : 0.5 second time constant 3 1 : 1 second time constant 4 2 : 2 seconds time constant 5 5 : 5 seconds time constant 6 10 : 10 seconds time constant 7 20 : 20 seconds time constant 8 30 : 30 seconds time constant 9 60 : 60 seconds time constant	2
OUT1	Output 1 Function	2 Hi. : High limit control 3 Lo. : Low limit control 4 Hi.Lo : High/Low limit control	2

3-4 PV Shift

In certain application it is desirable to shift the indicated value from its actual value. This can be easily accomplished with this unit by using the PV shift function.

Cycle the unit to the SHIF parameter by using the scroll key. The number you adjust here, either positive or negative, will be added to the actual value. The SHIF function will **alter PV only**.

SHIF: PV shift (input correction) value

3-5 Digital Filter

In certain applications the process value is too unstable to be read. To improve this a programmable low pass filter incorporated in the L91 can be used. This is a first order filter with time constant specified by FILT parameter which is contained in setup menu. The FILT is defaulted to 0.5 sec. before shipping. Adjust FILT to change the time constant from 0 to 60 seconds. 0 second represents no filter is applied to the input signal. The filter is characterized by the following diagram.

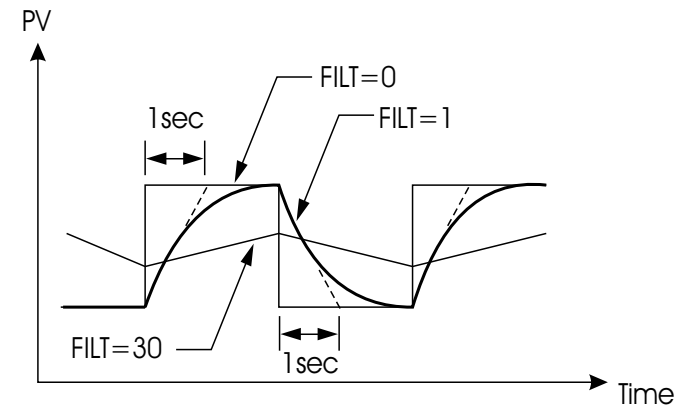

Figure 3-2 Filter Characteristics

Formula: $PV = IN.LO + (IN.HI - IN.LO) \frac{S-SL}{SH-SL}$

Example: a 4-20 mA current loop pressure transducer with range 0 - 15 kg/cm², is connected to input, then perform the following setup:

INPT = 4-20 mA IN.LO = 0.0
 UNIT = PU IN.HI = 15.0
 RESO = 1-DP

Of course, you may select other value for RESO to alter the resolution.

3-2 Limit Control

O1.HY: Output 1 hysteresis value. The hysteresis value is adjusted to a proper value to eliminate the relay jitter in a noisy environment.

3-3 Set Point Range

HSRL : Lower limit of HSP1
 Hidden if LO is selected for OUT1

HSPH : Upper limit of HSP1
 Hidden if LO is selected for OUT1

LSPL : Lower limit of LSP1
 Hidden if HI is selected for OUT1

LSPH : Upper limit of LSP1
 Hidden if HI is selected for OUT1



HSP.L and HSP.H in setup menu are used to confine the adjustment range of HSP1. LSPL and LSP.H are used to confine the adjustment range of LSP1.

Parameter Notation	Parameter Description	Range	Default Value
O1.HY	Output 1 Hysteresis Value	Low: 0.1 High: 10.0°C (18.0°F)	0.1
HSP.L	Lower Limit of HSP1	Low: -19999 High: HSP.H	0°C (32.0°F)
HSP.H	Upper Limit of HSP1	Low: HSP.L High: 45536	1000.0°C (1832.0°F)
LSPL	Lower Limit of LSP1	Low: -19999 High: LSP.H	-100.0°C (-148.0°F)
LSP.H	Upper Limit of LSP1	Low: LSPL High: 45536	0°C (32.0°F)
OUT 2	Output 2 Function	0 <i>nonE</i> : No Function 1 <i>dCPS</i> : DC power supply output 2 <i>Coññ</i> : RS-485 Communication 3 <i>ALñ</i> : Alarm output 4 <i>L_Añ</i> : Limit annunciator 5 <i>E,Fn</i> : Event input	—
ADDR	Address Assignment of Digital COMM	Low: 1 High: 255	—
BAUD	Band Rate of Digital COMM	0 <i>0.3</i> : 0.3 Kbits/s baud rate 1 <i>0.6</i> : 0.6 Kbits/s baud rate 2 <i>1.2</i> : 1.2 Kbits/s baud rate 3 <i>2.4</i> : 2.4 Kbits/s baud rate 4 <i>4.8</i> : 4.8 Kbits/s baud rate	—

Parameter Notation	Parameter Description	Range	Default Value
BAUD	Band Rate of Digital COMM	5 <i>9.6</i> : 9.6 Kbits/s baud rate 6 <i>14.4</i> : 14.4 Kbits/s baud rate 7 <i>19.2</i> : 19.2 Kbits/s baud rate 8 <i>28.8</i> : 28.8 Kbits/s baud rate 9 <i>38.4</i> : 38.4 Kbits/s baud rate	5
PARI	Parity Bit of Digital COMM	0 <i>EVEN</i> : 8 bit even parity 1 <i>odd</i> : 8 bit odd parity 2 <i>none</i> : 8 bit none parity	0
AL.FN	Alarm function	6 <i>PYHA</i> : Process value high alarm 7 <i>PYLA</i> : Process value low alarm	5
AL.MD	Alarm mode	0 <i>norm</i> : Normal alarm action 1 <i>Ltch</i> : Latching alarm action	0
AL.HY	Alarm hysteresis value	Low: 0.1 High: 10°C (18.0°F)	0.1

Chapter 3 Programming

3-1 Process Input

Press  for 4 seconds to enter setup mode. Press  to select the parameter. The display will indicate the parameter symbol and the value (or selection) for that parameter.

INPT: Selects the sensor type and signal type for the process input.

UNIT: Selects the process unit.

RESO: Selects the location of the decimal point (Resolution) for most (not all) process related parameters.

IN.LO: Selects the low scale value for the Linear type input
Hidden if: T/C or RTD type is selected for INPT

IN.HI: Selects the high scale value for the Linear type input
Hidden if: T/C or RTD type is selected for INPT

How to use IN.LO and IN.HI:

If 4-20mA is selected for INPT, let SL specifies the input signal low (ie. 4mA), SH specifies the signal high (ie. 20mA), S specifies the current input signal value, the conversion curve of the process value is shown as follows:

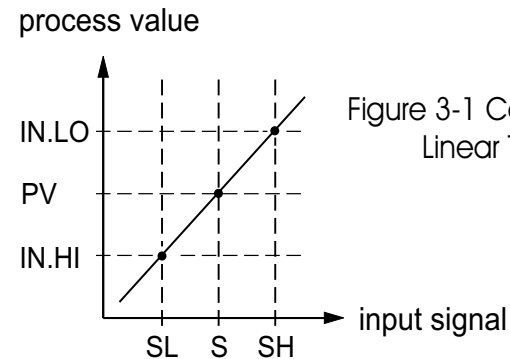

Figure 3-1 Conversion Curve for Linear Type Process Value

Chapter 2 Installation

⚠ Dangerous voltages capable of causing death are present in this instrument. Before installation or beginning any troubleshooting procedures the power to all equipment must be switched off and isolated. Units suspected of being faulty must be disconnected and removed to a properly equipped workshop for testing and repair. Component replacement and internal must be made by a qualified maintenance person only.

⚠ To minimize the possibility of fire or shock hazards, do not expose this instrument to rain or excessive moisture.

⚠ Do not use this instrument in areas under hazardous conditions such as excessive shock, vibration, dirt, moisture, corrosive gases or oil. The ambient temperature of the areas should not exceed the maximum rating specified in Chapter 6.

2 - 1 Unpacking

Upon receipt of the shipment remove the unit from the carton and inspect the unit for shipping damage. If any damage due to transit, report and claim with the carrier. Write down the model number, serial number, and date code for future reference when corresponding with our service center. The serial number (S/N) and date code (D/C) are labeled on the box and the housing of the unit.

2 - 2 Mounting

Make panel cutout to dimension shown in Figure 2-1.

2-11 Output 2 Wiring

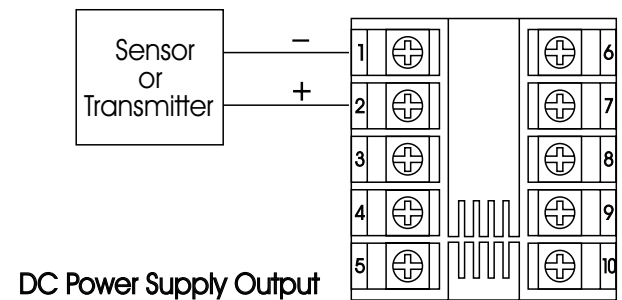
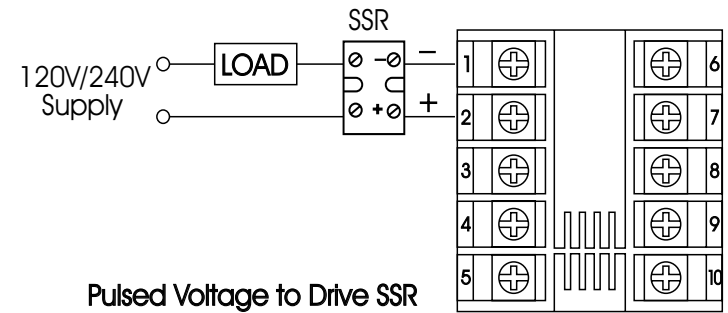
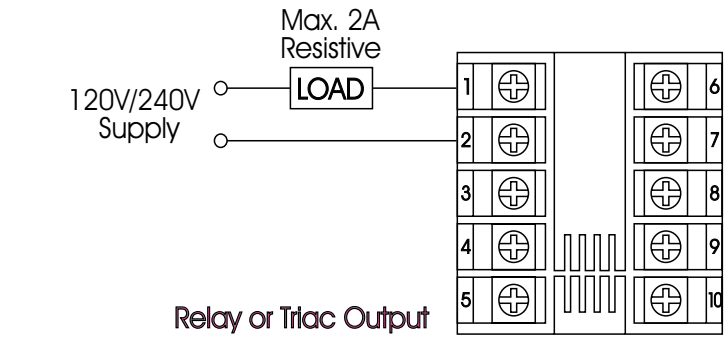
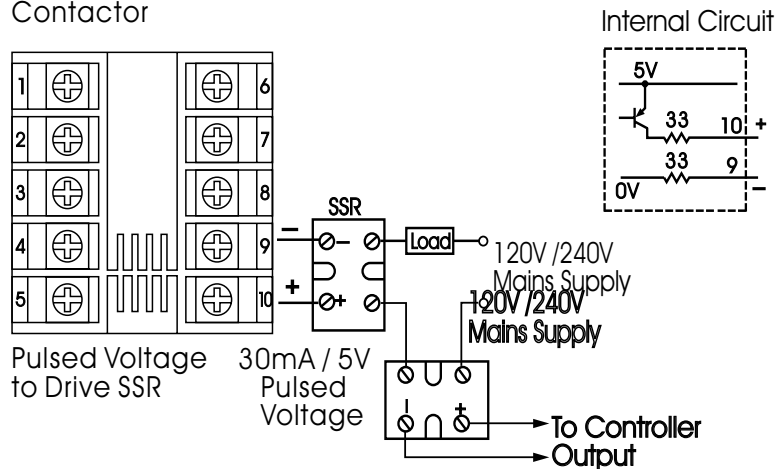
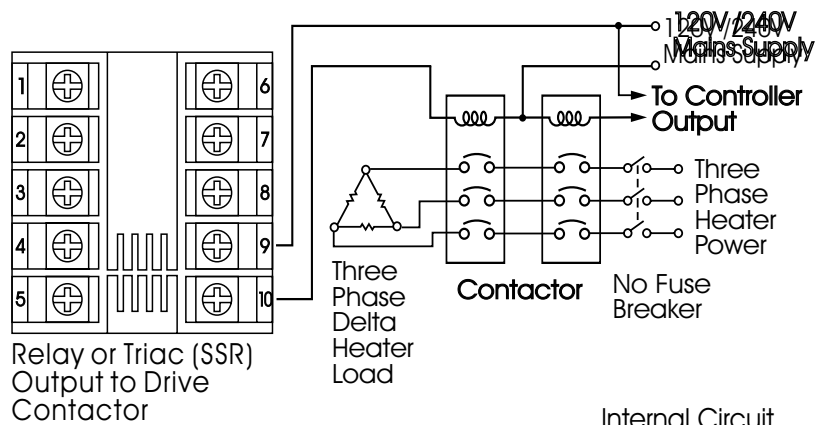
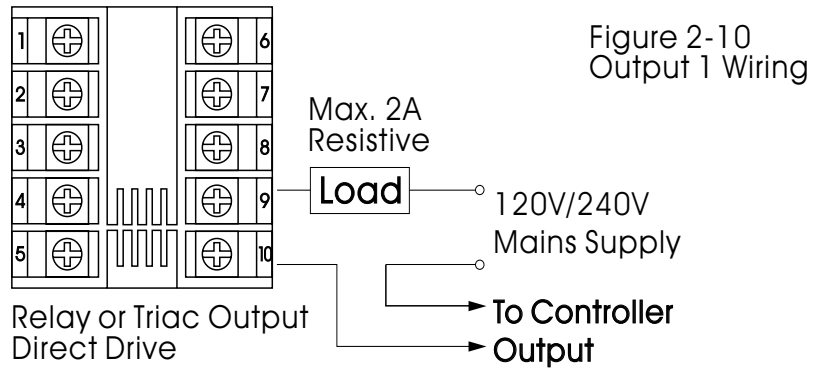

Figure 2-11 Output 2 Wiring

2-10 Output 1 Wiring



Install both mounting clamps and insert the housing into panel cutout.

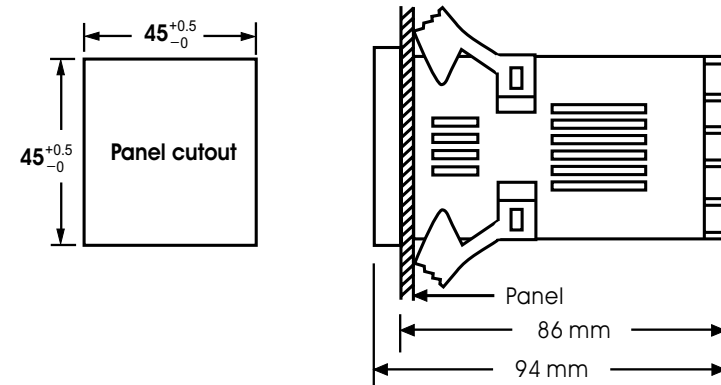

Figure 2-1 Mounting Diagram

2 - 3 Wiring Precautions

- ★ Before wiring, verify the label for correct model number and options. Switch off the power when checking.
- ★ Care must be taken to ensure that maximum voltage rating specified on the label are not exceeded.
- ★ It is recommended that power of these units to be protected by fuses or circuit breakers rated at the minimum value possible.
- ★ All units should be installed inside a suitably grounded metal enclosure to prevent live parts being accessible from human hands and metal tools.
- ★ All wiring must conform to appropriate standards of good practice and local codes and regulations. Wiring must be suitable for maximum voltage, current, and temperature rating of the system.
- ★ Take care not to over-tighten the terminal screws.

- * Unused control terminals should not be used as jumper points as they may be internally connected, causing damage to the unit.
- * Verify that the ratings of the output devices and the inputs as specified in Chapter 6 are not exceeded.
- * Electric power in industrial environments contains a certain amount of noise in the form of transient voltage and spikes. This electrical noise can enter and adversely affect the operation of microprocessor-based controls. For this reason we strongly recommend the use of shielded thermocouple extension wire which connects the sensor to the unit. This wire is a twisted-pair construction with foil wrap and drain wire. The drain wire is to be attached to earth ground at the sensor end only.

2-9 Event Input wiring

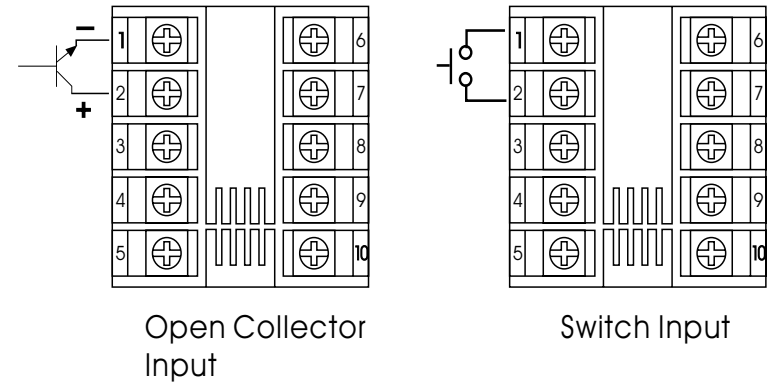

Figure 2-9
Event Input Wiring

The event input can accept a switch signal as well as an open collector signal. The event input function (EIFN) is activated as the switch is closed or an open collector (or a logic signal) is pulled down.

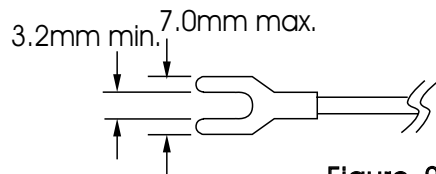

Figure 2-2 Lead Termination

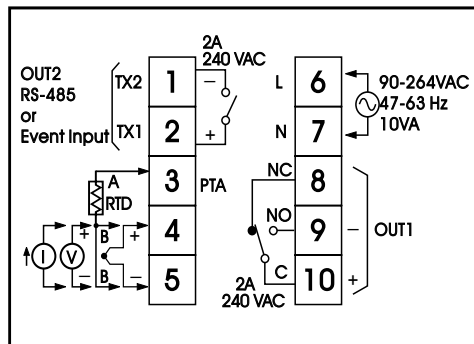

Figure 2-3 Rear Terminal
Connection Diagram

2-8 Linear DC Input Wiring

DC linear voltage and linear current connections are shown in Figure 2-7 and Figure 2-8 .

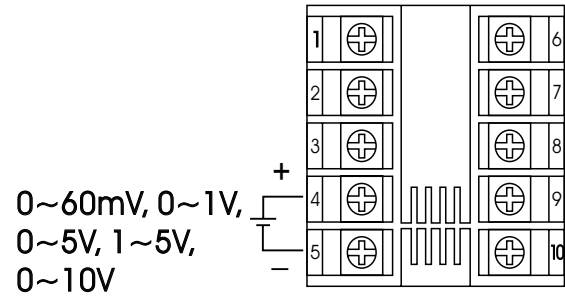

Figure 2.7
Linear Voltage Input Wiring *

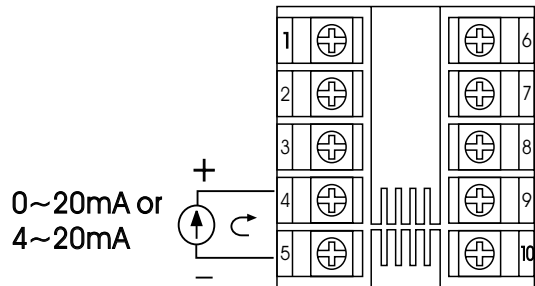

Figure 2.8
Linear Current Input Wiring *

NOTE: Volt and Milliamp inputs are NOT FM Approved.

2-4 Power Wiring

The unit is supplied to operate at 11-26 VAC / VDC or 90-264VAC. Check that the installation voltage corresponds with the power rating indicated on the product label before connecting power to the unit.

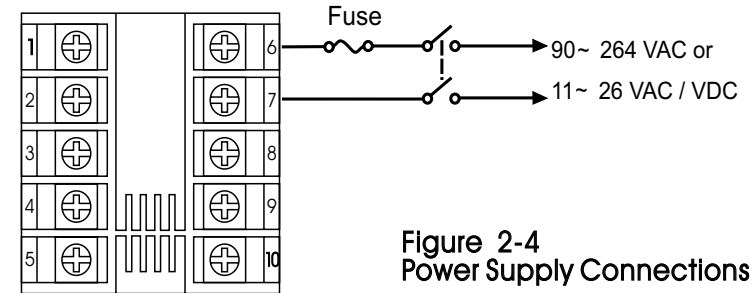

Figure 2-4
Power Supply Connections

! This equipment is designed for installation in an enclosure which provides adequate protection against electric shock. The enclosure must be connected to earth ground.

Local requirements regarding electrical installation should be rigidly observed. Consideration should be given to prevent from unauthorized person access to the power terminals.

2-5 Sensor Installation Guidelines

Proper sensor installation can eliminate many problems in a control system. The probe should be placed so that it can detect any temperature change with minimal thermal lag. In a process that requires fairly constant heat output, the probe should be placed close to the heater. In a process where the heat demand is variable, the probe should be closed to the work area. Some experiments with probe location are often required to find this optimum position.

In a liquid process, addition of a stirrer will help to eliminate thermal lag. Since the thermocouple is basically a point measuring device, placing more than one thermocouple in parallel will provide an average temperature readout and produce better results in most air heated processes.

Proper sensor type is also a very important factor to obtain precise measurements. The sensor must have the correct temperature range to meet the process requirements. In special processes the sensor might need to have different requirements such as leak-proof, anti-vibration, antiseptic, etc.

Standard thermocouple sensor limits of error are ± 4 degrees F (± 2 degrees C) or 0.75% of sensed temperature (half that for special) plus drift caused by improper protection or an over-temperature occurrence. This error is far greater than controller error and cannot be corrected at the sensor except by proper selection and replacement.

2-6 Thermocouple Input Wiring

Thermocouple input connections are shown in Figure 2-5. The correct type of thermocouple extension lead-wire or compensating cable must be used for the entire distance between the unit and the thermocouple, ensuring that the correct polarity is observed throughout. Joints in the cable should be avoided, if possible.

If the length of thermocouple plus the extension wire is too long, it may affect the temperature measurement. A 400 ohms K type or a 500 ohms J type thermocouple lead resistance will produce approximately 1 degree C temperature error .

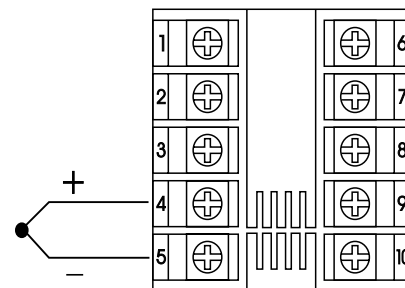

Figure 2.5
Thermocouple Input Wiring

2-7 RTD Input Wiring

RTD connection are shown in Figure 2-6, with the compensating lead connected to terminal 4. For two-wire RTD inputs, terminals 4 and 5 should be linked. The three-wire RTD offers the capability of lead resistance compensation provided that the three leads are of same gauge and equal length.

Two-wire RTD should be avoided, if possible, for the purpose of accuracy. A 0.4 ohm lead resistance of a two-wire RTD will produce 1 degree C temperature error.

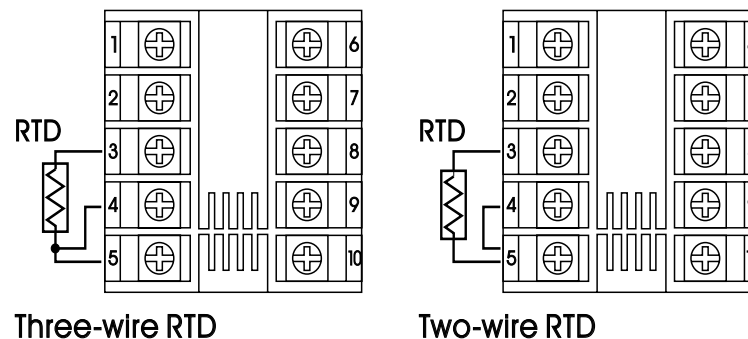

Figure 2-6
RTD Input Wiring